

# The Sixth Form at George Abbot

Pre Sixth Form Tasks 2025



Subject: **A-Level Mathematics and Further Maths**

Exam Board: **Edexcel**



Welcome to A-level Maths and Further Maths! We are delighted that you wish to continue studying maths in Year 12. To demonstrate your commitment to the course and to prepare you for September, please complete the following compulsory tasks to the best of your ability.

**Task 1: Complete at least one (and ideally two) of the summer booklets.**

**Task 2: Prepare your folders.**

**These tasks are mandatory and must be completed prior to your first Year 12 maths lesson. Please bring your completed work to that lesson. Your teachers will sign off that the work is complete.**

We expect you to spend at least 4 hours on these summer tasks. The booklets are designed to ensure you have mastered the essential GCSE skills required for A-level Maths. All the questions are based on topics you have studied at GCSE but will explore further in A-level Maths.

Please complete the questions on A4 lined paper and show all your workings. You may use your notes, revision guides, textbooks, or the internet to assist you.

We look forward to seeing you in September and wish you an enjoyable and productive summer!

Contact for Support:

Ms Howarth - KS5 Maths Lead

[lhowarth@georgeabbot.surrey.sch.uk](mailto:lhowarth@georgeabbot.surrey.sch.uk)



### Task 1: Summer Booklets

Booklets can be found on the school website - Sixth Form - Induction - Maths

#### Level 1 Booklet - Introduce

Most suitable for students who expect to get grade 6 or 7 at GCSE

#### Level 2 Booklet - Strengthen

Most suitable for students who expect to get grade 7 or 8 at GCSE

#### Level 3 Booklet - Deepen

Most suitable for students who expect to get grade 8 or 9 at GCSE

Please be aware that you will be given a baseline test at the start of the new term. For single maths students this will be in your first lesson. For further maths students this will be in the second week of the new term and will cover Chapters 1-4 of the Pure Mathematics Year 1 book.

### Task 2: Prepare folders

Set up two folders - Pure and Applied. Each folder should have dividers for each chapter and a separate divider for assessments:

Pure: Chapters 1 -14

Applied: Chapters 1-11

Include the Specification (Pages 15-32) for A level maths in your folders.

[Link to Subject Specification](#)

<https://qualifications.pearson.com/en/qualifications/edexcel-a-levels/mathematics-2017/coursematerials.html#filterQuery=Pearson-UK:Category%2FSpecification-and-sample-assessments>

# The Sixth Form at George Abbot

Pre Sixth Form Tasks 2025



## Course equipment/books



### Calculators:

You must have the new CASIO FX-991CW calculator (c£27) or the CASIO FX-CG50 or FX-CG100 (c£90) - which you can purchase on Wisepay or try ebay etc for secondhand.

### Books:

Textbooks new and used can be purchased online or you can borrow them from the library but there are only a limited number. We do recommend having a physical book. In addition to the books, you can have digital access. New books and some secondhand books come with digital access codes.

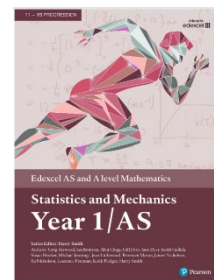
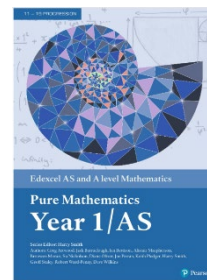

Sparx Maths

# Transition Workbook

GCSE to A-Level

Level 1 - Introduce



[sparxmaths.com](https://sparxmaths.com)

In this booklet, there are a range of questions from key topics that you will have seen in GCSE and will be helpful for AS Level and A-Level.

Each topic has three sections:

- **Introduce** questions allow you to practise the key concepts.
- **Strengthen** questions build on your knowledge of the key concepts.
- **Deepen** questions will challenge your understanding.

Unless otherwise indicated, you may use a calculator.

Use the grid below to keep track of your progress in each topic. Tick the sections you have attempted. If you use Sparx Maths you can find even more questions by searching for the Sparx topic codes in Independent Learning.

	I	S	D	Sparx topic codes	Teacher comment
Surds	<input type="radio"/>	<input type="radio"/>	<input type="radio"/>	U499 U707 U281	_____
Expanding brackets	<input type="radio"/>	<input type="radio"/>	<input type="radio"/>	U768 U606	_____
Factorising quadratics	<input type="radio"/>	<input type="radio"/>	<input type="radio"/>	U178 U858	_____
Simplifying expressions	<input type="radio"/>	<input type="radio"/>	<input type="radio"/>	U662 U437	_____
Operations with algebraic fractions	<input type="radio"/>	<input type="radio"/>	<input type="radio"/>	U685 U457 U824	_____
Solving quadratic equations	<input type="radio"/>	<input type="radio"/>	<input type="radio"/>	U228 U960 U665 U150	_____
Quadratic graphs	<input type="radio"/>	<input type="radio"/>	<input type="radio"/>	U589 U769 U601	_____
Linear simultaneous equations	<input type="radio"/>	<input type="radio"/>	<input type="radio"/>	U760 U757	_____
Straight-line graphs	<input type="radio"/>	<input type="radio"/>	<input type="radio"/>	U315 U477 U848 U669 U377 U898	_____
Right-angled trigonometry	<input type="radio"/>	<input type="radio"/>	<input type="radio"/>	U283 U545 U170	_____
Further trigonometry	<input type="radio"/>	<input type="radio"/>	<input type="radio"/>	U952 U591	_____

## Key facts and formulae:

### The Quadratic formula:

The solution of  $ax^2 + bx + c = 0$

where  $a \neq 0$

$$x = \frac{-b \pm \sqrt{b^2 - 4ac}}{2a}$$

---

### Trigonometry:

In any right-angled triangle  $ABC$  where  $a$ ,  $b$  and  $c$  are the length of the sides and  $c$  is the hypotenuse:

$$\sin A = \frac{a}{c} \quad \cos A = \frac{b}{c} \quad \tan A = \frac{a}{b}$$

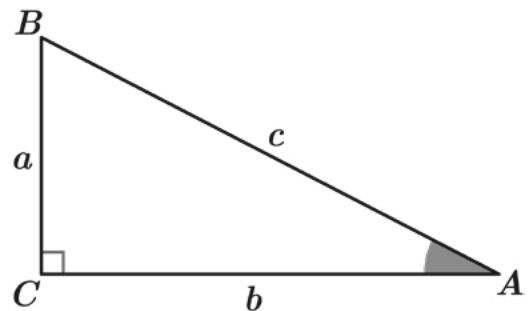

In any triangle  $ABC$  where  $a$ ,  $b$  and  $c$  are the length of the sides:

$$\text{sine rule: } \frac{a}{\sin A} = \frac{b}{\sin B} = \frac{c}{\sin C}$$

$$\text{cosine rule: } a^2 = b^2 + c^2 - 2bc \cos A$$

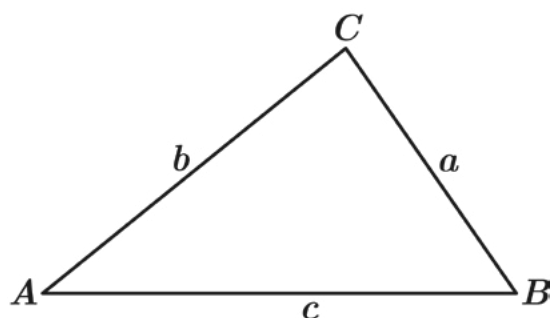

Q1

Expand and fully simplify  $\sqrt{5}(\sqrt{5} + \sqrt{7})$ 

Answer: .....

Q2

Rationalise the denominator of  $\frac{2\sqrt{5}}{\sqrt{6}}$   
Give your answer in its simplest form.

Answer: .....

Q3

Expand and fully simplify  $(6 + \sqrt{5})(1 + \sqrt{5})$ 

Answer: .....

Q4

Write  $(5 + \sqrt{12})(11 + \sqrt{3})$  in the form  $a + b\sqrt{3}$ , where  $a$  and  $b$  are integers.

Answer: .....

Q5

Rationalise the denominator of  $\frac{1 + \sqrt{2}}{\sqrt{2}}$

Give your answer as a fraction in its simplest form.

Answer: .....

Q1

Expand and fully simplify  $(m + 9)(m + 2)$ 

Answer: .....

Q2

Expand and fully simplify  $(2a + 3)(4a + 5)$ 

Answer: .....

Q3

Expand and fully simplify  $(x - 3)(4x + 9)$ 

Answer: .....

Q4

Expand and fully simplify  $(6n - 5)^2$ 

Answer: .....

Q1

Fully factorise  $y^2 + 9y + 20$ 

Answer: .....

Q2

Fully factorise  $x^2 - x - 20$ 

Answer: .....

Q3

Fully factorise  $w^2 - 15w + 54$ 

Answer: .....

Q1

Fully simplify the expression  $4y^5 \times 3y^2$ 

Answer: .....

Q2

Simplify  $(h^{-5})^3$ 

Give your answer without any negative indices.

Answer: .....

Q3

Write  $\frac{2t^6u}{8t^3}$  as a fraction in its simplest form.

Answer: .....

Q4

Fully simplify  $\left(\frac{t^3}{u^5}\right)^2$ 

Answer: .....

Q5

Write  $\frac{33xy + 9x}{18x}$  as a fraction in its simplest form.

Answer: .....

Q6

Fully simplify  $\frac{6a + 42}{a^2 + 11a + 28}$ 

Answer: .....

Q1

Fully simplify  $\frac{14a}{b} \times \frac{b}{2}$

Answer: .....

Q2

Fully simplify  $\frac{6a}{v} \div \frac{2a}{5}$

Give your answer as a fraction.

Answer: .....

Q3

Fully simplify the expression below to give a single fraction.

$$\frac{n+2}{5} + \frac{6n}{7}$$

Answer: .....

Q1

Find the two solutions to the equation

$$(x - 9)(x + 5) = 0$$

Answer: .....

Q2

Solve this equation by factorising:

$$y^2 + 3y - 10 = 0$$

Answer: .....

Q3

Solve this equation by factorising:

$$12 - 8w + w^2 = 0$$

Answer: .....

Q4

Using the quadratic formula, solve

$$4x^2 + 16x + 15 = 0$$

Answer: .....

Q5

Solve this equation by factorising:

$$2m^2 - 11m + 5 = 0$$

Answer: .....

Q1

Write down the coordinates of the roots of the quadratic curve shown below.

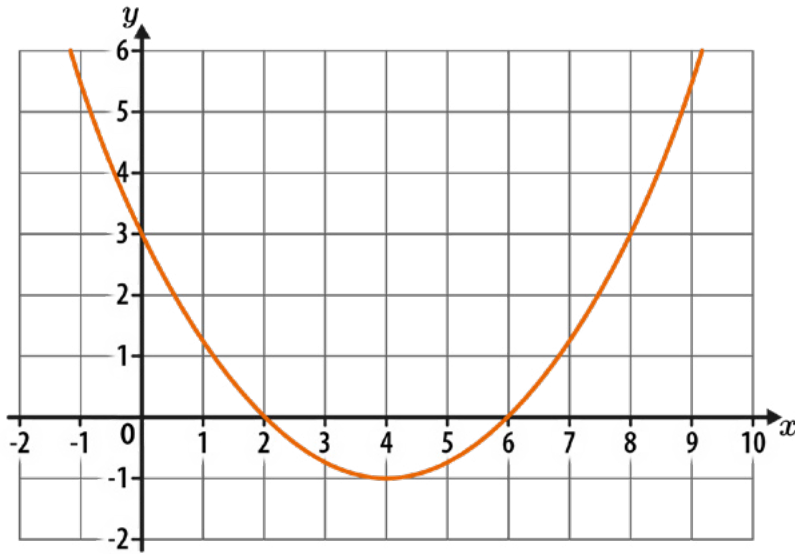

Answer: ( ..... , ..... ) and ( ..... , ..... )

Q2

Here is the graph of the function  $y = x^2 + x - 5$

Estimate the solutions to  $x^2 + x - 5 = 0$   
Give your answers to 1 d.p.

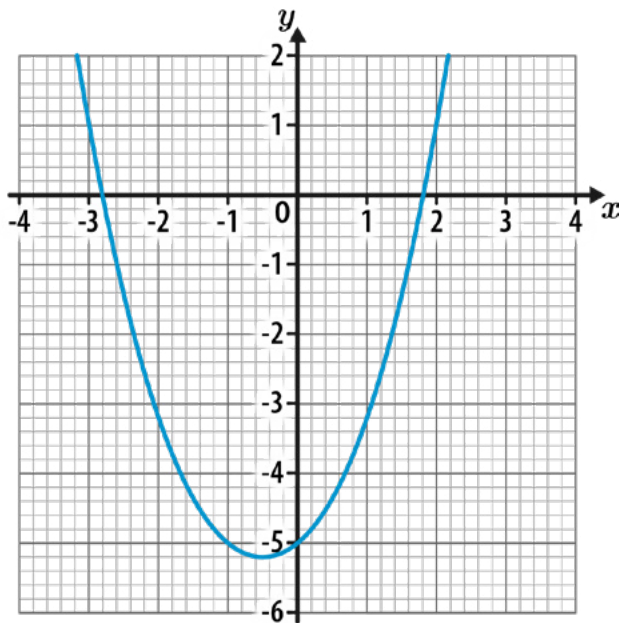

Answer: .....

Q3

The diagram below shows the graph of the function  $y = 2x^2 + 2x - 7$

Work out the solutions to  $2x^2 + 2x - 7 = -3$

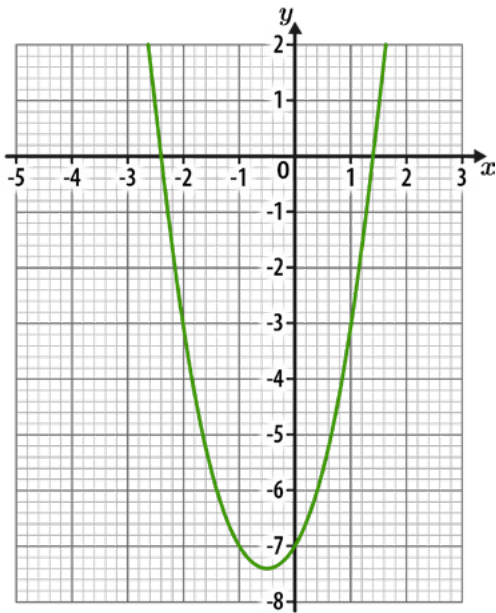

Answer: .....

Q4

a) Write  $x^2 + 6x + 11$  in the form  $(x + c)^2 + d$ , where  $c$  and  $d$  are numbers.

Answer: a) .....

b) Hence, write down the coordinates of the turning point on the curve  $y = x^2 + 6x + 11$

Answer: b) ( ..... , ..... )

**Q1**

Solve the following simultaneous equations:

$$6x + y = 22$$

$$2x + y = 10$$

Answer:  $x = \dots\dots\dots$   $y = \dots\dots\dots$

**Q2**

Solve the following simultaneous equations:

$$7x - 4y = 20$$

$$2x + 4y = 16$$

Answer:  $x = \dots\dots\dots$   $y = \dots\dots\dots$

**Q3**

Solve the following simultaneous equations:

$$15a - 4b = 25$$

$$5a + 2b = 25$$

Answer:  $a = \dots\dots\dots$   $b = \dots\dots\dots$ **Q4**

Solve the following simultaneous equations:

$$2x + 3y = 8$$

$$3x + 4y = 11$$

Answer:  $x = \dots\dots\dots$   $y = \dots\dots\dots$

**Q1** Work out the equation of the straight line shown below.

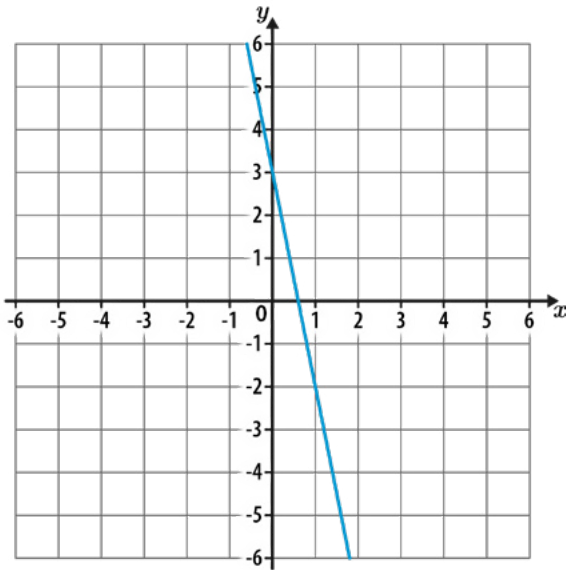

Answer: .....

**Q2** Work out the equation of the straight line that is parallel to line A and passes through point P.

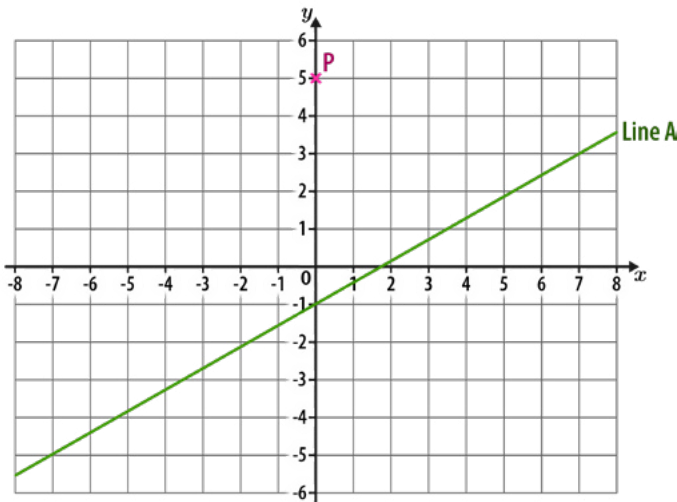

Answer: .....

**Q3** Line A has the equation  $2y - 10 = 16x$   
Line B is perpendicular to Line A.

What is the gradient of Line B?

Answer: .....

Q4

A straight line has a gradient of 3 and passes through the point (2, 10)

Work out the equation of the line.

Answer: .....

Q5

Work out the equation of the straight line that passes through (2, 3) and (5, 18)

Answer: .....

Q1

Work out the length  $g$ .  
Give your answer to 1 d.p.

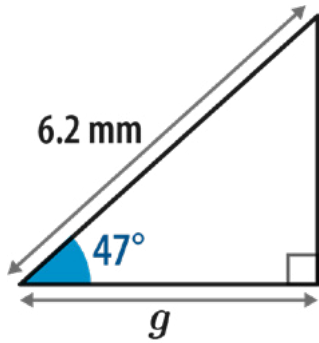

Not drawn accurately

Answer: ..... mm

Q2

Work out the length  $k$ .  
Give your answer to 1 d.p.

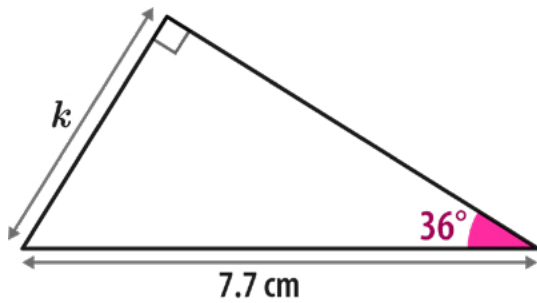

Not drawn accurately

Answer: ..... cm

Q3

Calculate the size of angle  $y$ .  
Give your answer to the nearest integer.

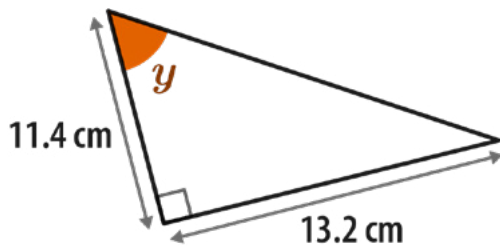

Not drawn accurately

Answer: ..... °

**Q1** Using the sine rule, calculate the length  $x$ .  
Give your answer to 1 d.p.

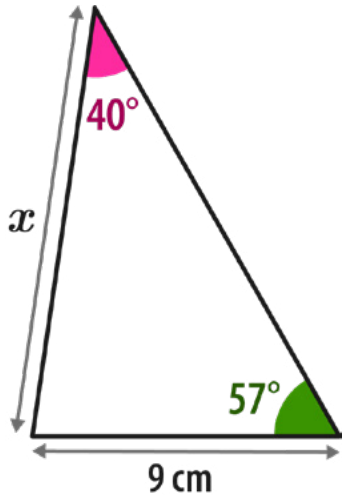

Not drawn accurately

Answer: ..... cm

**Q2** Using the cosine rule, work out the length  $y$ .  
Give your answer to 1 d.p.

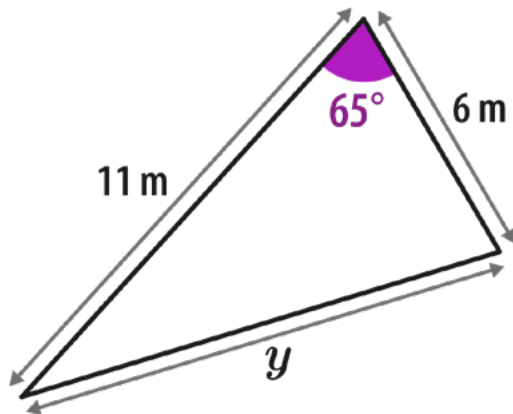

Not drawn accurately

Answer: ..... m

Q3

Use the sine rule to calculate angle  $\theta$ .  
Give your answer to 1 d.p.

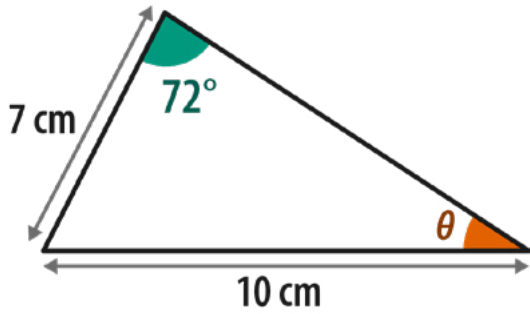

Not drawn accurately

Answer: .....<sup>o</sup>

Q4

Use the cosine rule to calculate the size of angle  $x$ .  
Give your answer to the nearest degree.

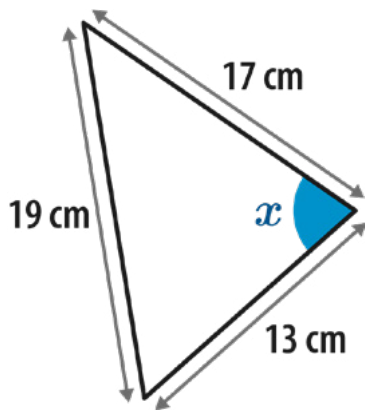

Not drawn accurately

Answer: .....<sup>o</sup>

Sparx Maths

# Transition Workbook

GCSE to A-Level

Level 2 - Strengthen



[sparxmaths.com](https://sparxmaths.com)

In this booklet, there are a range of questions from key topics that you will have seen in GCSE and will be helpful for AS Level and A-Level.

Each topic has three sections:

- **Introduce** questions allow you to practise the key concepts.
- **Strengthen** questions build on your knowledge of the key concepts.
- **Deepen** questions will challenge your understanding.

Unless otherwise indicated, you may use a calculator.

Use the grid below to keep track of your progress in each topic. Tick the sections you have attempted. If you use Sparx Maths you can find even more questions by searching for the Sparx topic codes in Independent Learning.

	I	S	D	Sparx topic codes	Teacher comment
Surds	<input type="radio"/>	<input type="radio"/>	<input type="radio"/>	U499 U707 U281	_____
Expanding brackets	<input type="radio"/>	<input type="radio"/>	<input type="radio"/>	U768 U606	_____
Factorising quadratics	<input type="radio"/>	<input type="radio"/>	<input type="radio"/>	U178 U858	_____
Simplifying expressions	<input type="radio"/>	<input type="radio"/>	<input type="radio"/>	U662 U437	_____
Operations with algebraic fractions	<input type="radio"/>	<input type="radio"/>	<input type="radio"/>	U685 U457 U824	_____
Solving quadratic equations	<input type="radio"/>	<input type="radio"/>	<input type="radio"/>	U228 U960 U665 U150	_____
Quadratic graphs	<input type="radio"/>	<input type="radio"/>	<input type="radio"/>	U589 U769 U601	_____
Linear simultaneous equations	<input type="radio"/>	<input type="radio"/>	<input type="radio"/>	U760 U757	_____
Straight-line graphs	<input type="radio"/>	<input type="radio"/>	<input type="radio"/>	U315 U477 U848 U669 U377 U898	_____
Right-angled trigonometry	<input type="radio"/>	<input type="radio"/>	<input type="radio"/>	U283 U545 U170	_____
Further trigonometry	<input type="radio"/>	<input type="radio"/>	<input type="radio"/>	U952 U591	_____

## Key facts and formulae:

### The Quadratic formula:

The solution of  $ax^2 + bx + c = 0$

where  $a \neq 0$

$$x = \frac{-b \pm \sqrt{b^2 - 4ac}}{2a}$$

---

### Trigonometry:

In any right-angled triangle  $ABC$  where  $a$ ,  $b$  and  $c$  are the length of the sides and  $c$  is the hypotenuse:

$$\sin A = \frac{a}{c} \quad \cos A = \frac{b}{c} \quad \tan A = \frac{a}{b}$$

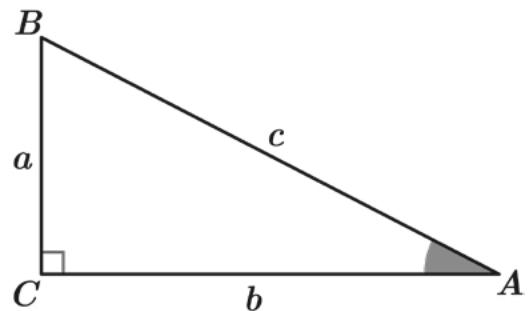

In any triangle  $ABC$  where  $a$ ,  $b$  and  $c$  are the length of the sides:

$$\text{sine rule: } \frac{a}{\sin A} = \frac{b}{\sin B} = \frac{c}{\sin C}$$

$$\text{cosine rule: } a^2 = b^2 + c^2 - 2bc \cos A$$

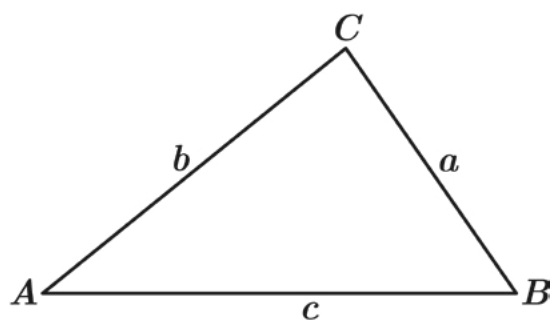

Q1

Expand and fully simplify  $(2\sqrt{6} - 5\sqrt{2})^2$ 

Answer: .....

Q2

Rationalise the denominator of  $\frac{15 + \sqrt{3}}{10\sqrt{3}}$ 

Give your answer as a fraction in its simplest form.

Answer: .....

Q3

Rationalise the denominator of  $\frac{2\sqrt{7}}{3+\sqrt{7}}$   
Give your answer in its simplest form.

Answer: .....

Q4

Write  $\sqrt{12} + \frac{33}{\sqrt{3}}$  in the form  $r\sqrt{3}$ , where  $r$  is an integer.

Answer: .....

Q1

Expand and fully simplify  $2(4d + 5)(3d + 1)$ 

Answer: .....

Q2

Expand and fully simplify  $(x + 1)(x^2 + 3x + 5)$ 

Answer: .....

**Q3** Expand and fully simplify  $(3n + 4)(5n + 2) + 5(n + 7)$

Answer: .....

**Q4** Expand and fully simplify  $(t - 2)(t + 5)(t - 4)$

Answer: .....

Q1

Fully factorise  $x^2 - 16$ 

Answer: .....

Q2

Fully factorise  $2r^2 + 15r + 7$ 

Answer: .....

Q3

Fully factorise  $5x^2 + 22x + 8$ 

Answer: .....

Q1

Write  $\frac{(3a)^2}{54ak}$  as a fraction in its simplest form.

Answer: .....

Q2

Fully simplify  $(64g^8h^4)^{\frac{1}{2}}$

Answer: .....

Q3

Fully simplify  $\frac{x+2}{2x^2-31x-70}$

Answer: .....

Q1

Fully simplify  $\frac{2}{5a+4} \times \frac{45a+36}{a}$

Give your answer as a fraction.

Answer: .....

Q2

Fully simplify  $\frac{6x}{(5x-7)(x+1)} - \frac{1}{5x-7}$

Give your answer fully factorised.

Answer: .....

**Q3** Write the following as a single fraction in its simplest form:

$$\frac{2x^2 - 11x + 12}{x + 5} \div (4x^2 - 6x)$$

Give your answer fully factorised.

Answer: .....

**Q4** Fully simplify  $\frac{4ab^2}{k} \times \frac{3ak}{12k} \times \frac{7}{5ab}$

Give your answer as a fraction.

Answer: .....

**Q1** Using the quadratic formula, solve  $y^2 - 6y + 7 = 0$

Give your answer in the form  $a \pm \sqrt{b}$

Answer: .....

**Q2** Solve the equation below using factorising.

$$6y^2 - 11y - 10 = 0$$

Answer: .....

**Q3** Using the quadratic formula, solve  $6x^2 - 35 = -11x$

Answer: .....

**Q4** Solve  $3r(3r - 4) = 2$   
Give your answers to 2 d.p.

Answer: .....

Q1

The diagram below shows a sketch of the curve  $y = x^2 + 8x - 10$

P is the turning point of the curve.

Work out the coordinates of P.

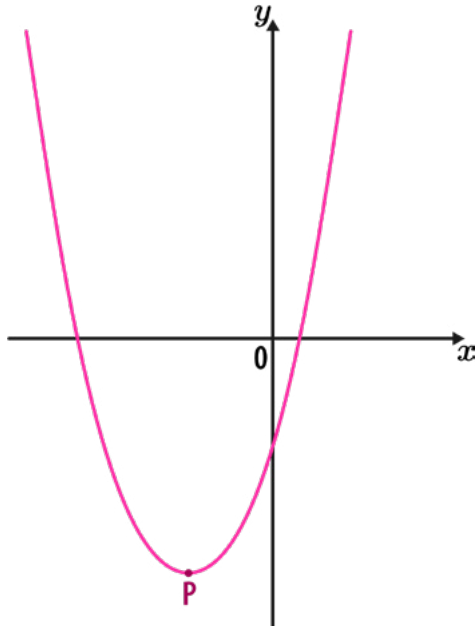

Answer: ( ..... , ..... )

Q2

Work out the coordinates of the turning point of the curve  $y = x^2 - 5x + 1$

Answer: ( ..... , ..... )

Sparx Maths

# Transition Workbook

GCSE to A-Level

Level 3 - Deepen



[sparxmaths.com](https://sparxmaths.com)

In this booklet, there are a range of questions from key topics that you will have seen in GCSE and will be helpful for AS Level and A-Level.

Each topic has three sections:

- **Introduce** questions allow you to practise the key concepts.
- **Strengthen** questions build on your knowledge of the key concepts.
- **Deepen** questions will challenge your understanding.

Unless otherwise indicated, you may use a calculator.

Use the grid below to keep track of your progress in each topic. Tick the sections you have attempted. If you use Sparx Maths you can find even more questions by searching for the Sparx topic codes in Independent Learning.

	I	S	D	Sparx topic codes	Teacher comment
Surds	<input type="radio"/>	<input type="radio"/>	<input type="radio"/>	U499 U707 U281	_____
Expanding brackets	<input type="radio"/>	<input type="radio"/>	<input type="radio"/>	U768 U606	_____
Factorising quadratics	<input type="radio"/>	<input type="radio"/>	<input type="radio"/>	U178 U858	_____
Simplifying expressions	<input type="radio"/>	<input type="radio"/>	<input type="radio"/>	U662 U437	_____
Operations with algebraic fractions	<input type="radio"/>	<input type="radio"/>	<input type="radio"/>	U685 U457 U824	_____
Solving quadratic equations	<input type="radio"/>	<input type="radio"/>	<input type="radio"/>	U228 U960 U665 U150	_____
Quadratic graphs	<input type="radio"/>	<input type="radio"/>	<input type="radio"/>	U589 U769 U601	_____
Linear simultaneous equations	<input type="radio"/>	<input type="radio"/>	<input type="radio"/>	U760 U757	_____
Straight-line graphs	<input type="radio"/>	<input type="radio"/>	<input type="radio"/>	U315 U477 U848 U669 U377 U898	_____
Right-angled trigonometry	<input type="radio"/>	<input type="radio"/>	<input type="radio"/>	U283 U545 U170	_____
Further trigonometry	<input type="radio"/>	<input type="radio"/>	<input type="radio"/>	U952 U591	_____

## Key facts and formulae:

### The Quadratic formula:

The solution of  $ax^2 + bx + c = 0$

where  $a \neq 0$

$$x = \frac{-b \pm \sqrt{b^2 - 4ac}}{2a}$$

---

### Trigonometry:

In any right-angled triangle  $ABC$  where  $a$ ,  $b$  and  $c$  are the length of the sides and  $c$  is the hypotenuse:

$$\sin A = \frac{a}{c} \quad \cos A = \frac{b}{c} \quad \tan A = \frac{a}{b}$$

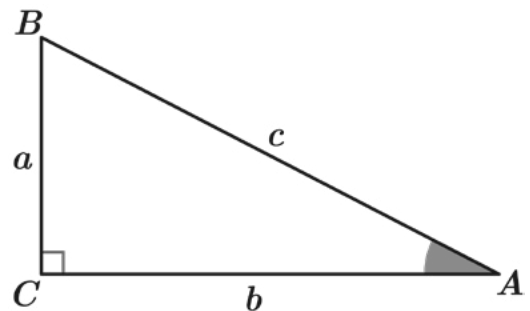

In any triangle  $ABC$  where  $a$ ,  $b$  and  $c$  are the length of the sides:

$$\text{sine rule: } \frac{a}{\sin A} = \frac{b}{\sin B} = \frac{c}{\sin C}$$

$$\text{cosine rule: } a^2 = b^2 + c^2 - 2bc \cos A$$

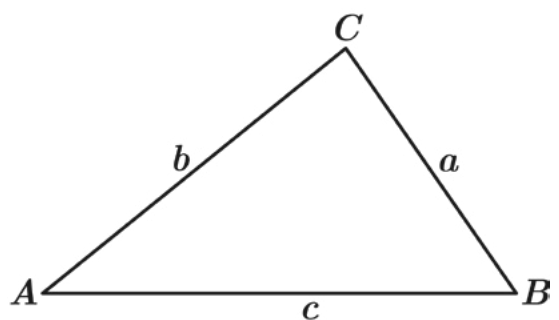

Q1

Expand and fully simplify  $(4 + \sqrt{7})^2 - (4 - \sqrt{7})^2$

Answer: .....

Q2

Work out the value of  $x$  in the equation below.

$$x(\sqrt{11} - 2) = 21$$

Give your answer in the form  $a + b\sqrt{11}$ , where  $a$  and  $b$  are integers.

Answer: .....

Q3

Given that  $h$  is a prime number, rationalise the denominator of  $\frac{5h - \sqrt{h}}{\sqrt{h}}$   
 Give your answer in its simplest form.

Answer: .....

Q4

Calculate the unknown side length, in metres, of the rectangle below.  
 Give your answer in its simplest form, rationalising the denominator if necessary.

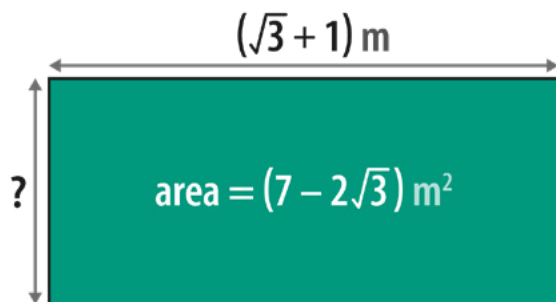

Answer: ..... m

Q1

Expand and fully simplify  $(2x + 5)(4x - 3)(5x - 4)$ 

Answer: .....

Q2

Work out the values of  $a$ ,  $b$  and  $c$  in the identity below.

$$(3x - 1)(x + 2)(ax + b) \equiv 15x^3 + 16x^2 - 25x + c$$

Answer:  $a = \dots\dots\dots$   $b = \dots\dots\dots$   $c = \dots\dots\dots$

Q3

Write the following expression in the form  $\frac{1}{ax^b} + \frac{1}{cy^d}$  where a, b, c, and d are integers.

$$\left(\frac{1}{5x} + \frac{1}{4y}\right)\left(\frac{1}{25x^2} - \frac{1}{20xy} + \frac{1}{16y^2}\right)$$

Answer: .....

Q4

Show that  $(x^2 + 1)(y^2 + 4) \equiv (xy - 2)^2 + (2x + y)^2$

**Q1** Work out the values of  $a$ ,  $b$  and  $c$  in the equality below.

$$\frac{2x^{20}y^4 \times 12x^4y^{26}}{(2xy^2)^3} = ax^by^c$$

Answer:  $a = \dots\dots\dots$   $b = \dots\dots\dots$   $c = \dots\dots\dots$

**Q2** Work out what expression should replace the ? in the equivalent fractions below.

$$\frac{?}{12r^4(t+6)} = \frac{2n}{3r}$$

Answer: ? = .....

**Q3**  $\frac{ax^2 + bx + c}{dx^2 - 25}$  simplifies to give  $\frac{x - 4}{2x - 5}$

Work out the values of  $a$ ,  $b$ ,  $c$  and  $d$  in the original fraction.

Answer:  $a = \dots\dots\dots$   $b = \dots\dots\dots$   $c = \dots\dots\dots$   $d = \dots\dots\dots$

Q1

Fully simplify  $\frac{7}{36 - x^2} - \frac{3}{6 + x}$

Give your answer fully factorised.

Answer: .....

Q2

Write the following as a single fraction in its simplest form:

$$6 - (x + 4) \div \frac{x^2 + 11x + 28}{x - 7}$$

Give your answer fully factorised.

Answer: .....

Q1

Solve  $x(x + 4) - 4(5x + 9) = 0$ 

Answer: .....

Q2

Jessica thinks of a positive number,  $n$ , which is less than 1  
She adds this number to its reciprocal and gets 2.9

Work out the value of  $n$ .

Give your answer as a fraction in its simplest form.

Answer: .....

Q1

The diagram below shows the graph of  $y = 2x^2 + 4x - 1$   
 The equation  $2x^2 + 4x - 1 = k$  has solutions at  $x = -3$  and  $x = 1$

What is the value of  $k$ ?

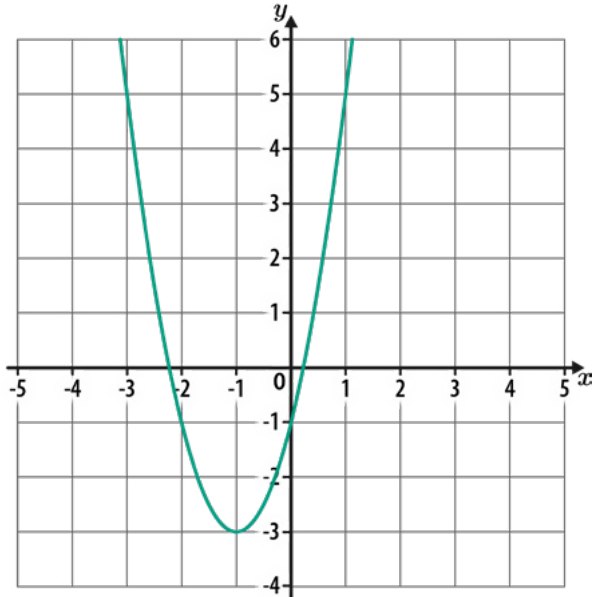

Answer:  $k = \dots\dots\dots$

Q2

A curve has the equation  $y = x^2 + ax + b$ , where  $a$  and  $b$  are numbers.  
 The turning point of the curve is  $(5, 4)$

Work out the values of  $a$  and  $b$ .

Answer:  $a = \dots\dots\dots$   $b = \dots\dots\dots$

Q3

A curve has the equation  $y = -x^2 + 16x - 65$

a) Work out the turning point of the curve.

Answer: a) ( ..... , ..... )

b) By considering the position of the turning point and the shape of the curve, work out how many real roots  $y = -x^2 + 16x - 65$  has.

Answer: b) .....

Q1

Solve the following simultaneous equations:

$$3x = 3 - 4y$$

$$12y + 11 = -5x$$

Answer:  $x = \dots\dots\dots$   $y = \dots\dots\dots$ 

Q2

Find the values of  $x$ ,  $y$  and  $a$  by solving the following simultaneous equations:

$$6x - 7y = -10$$

$$12x - 5y = 16$$

$$2x + ay = 10$$

Answer:  $x = \dots\dots\dots$   $y = \dots\dots\dots$   $a = \dots\dots\dots$

Q3

Solve the following simultaneous equations:

$$\frac{4}{7x-4} = \frac{1}{6y}$$

$$\frac{5x}{3y+2} = 4$$

Answer:  $x = \dots\dots\dots$   $y = \dots\dots\dots$ 

Q4

Solve the following simultaneous equations:

$$2^x = 4^{(7-2y)}$$

$$3^{(5x-13y)} = 81$$

Answer:  $x = \dots\dots\dots$   $y = \dots\dots\dots$

Q1

Write an expression, in terms of  $h$ , for the gradient of a line **perpendicular** to the line segment joining  $(3h, 20)$  to  $(6h, 8)$

Give your answer as a fully simplified fraction.

Answer: .....

Q2

The triangle ABC has an area of 24 square units.

What are the coordinates of point B?

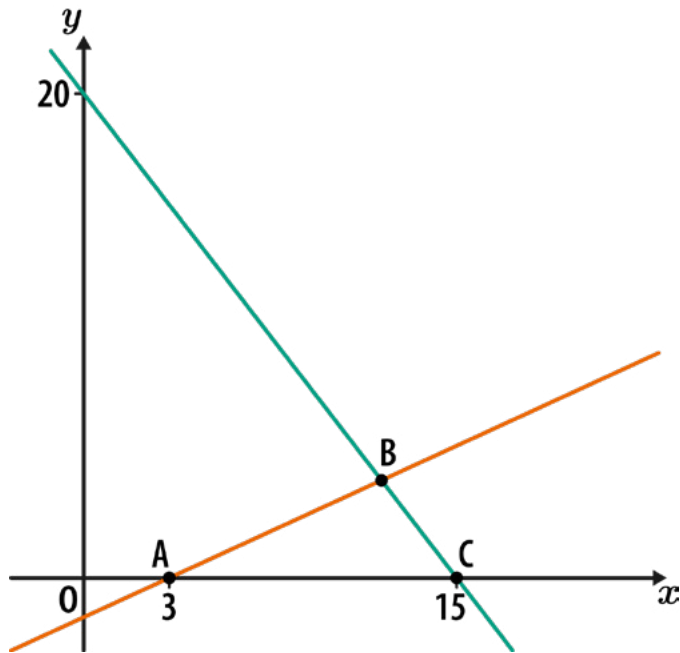

Answer: ( ..... , ..... )

**Q3** Line A has the equation  $y + 2x = 14$   
 The gradient of line B is twice the gradient of line A.  
 Work out the ratio of the length of OQ to the length of OR.  
 Give your answer in its simplest form.

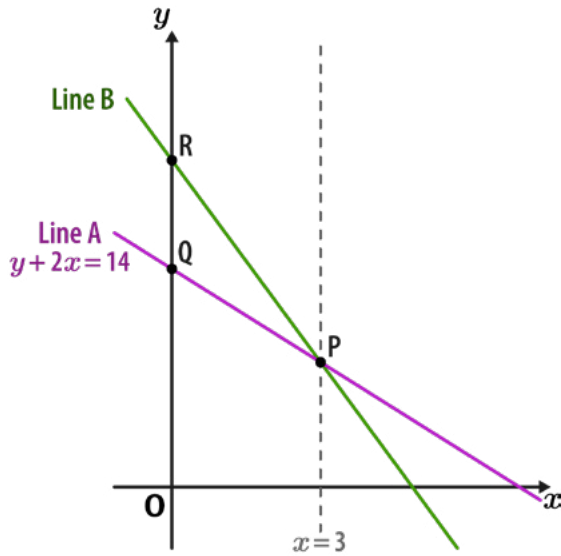

Answer: .....

**Q4** A circle, centre O, passes through the point (6, -12), as shown.  
 Work out the equation of the tangent to the circle at this point.  
 Give your answer in the form  $y = mx + c$ , where  $m$  and  $c$  are integers or fractions in their simplest form.

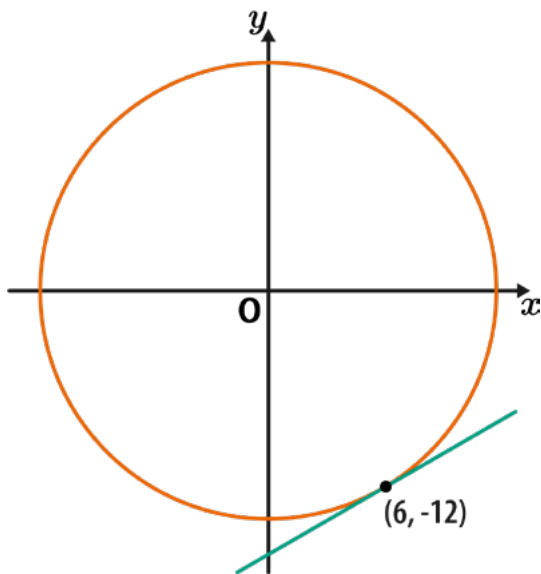

Answer: .....

Q1

Calculate the size of angle  $\theta$ .  
Give your answer to 1 d.p.

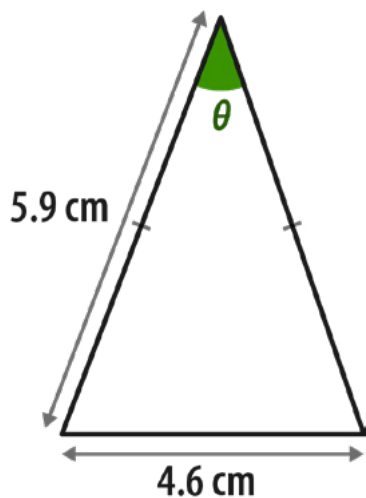

Not drawn accurately

Answer: .....<sup>o</sup>

Q2

Work out the length  $y$ .  
Give your answer to 2 d.p.



Not drawn accurately

Answer: ..... cm

**Q3** The graph below shows the line with equation  $y = 5x + 2$   
The axes both have the same scale.

Calculate the size of angle  $\theta$ .  
Give your answer in degrees to the nearest integer.

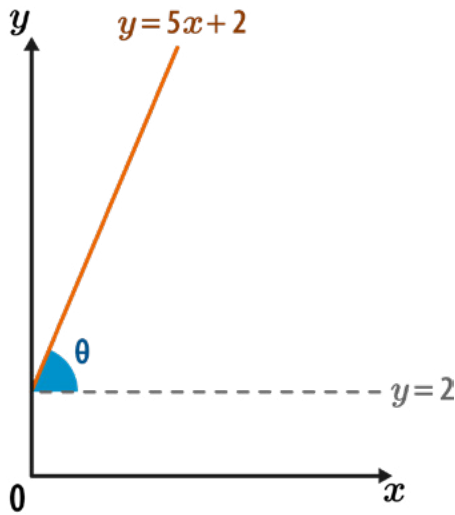

Not drawn accurately

Answer: ..... °

**Q4** The shape below is a regular hexagon.

Use trigonometry to calculate the distance  $p$ .  
Give your answer in centimetres to 2 d.p.

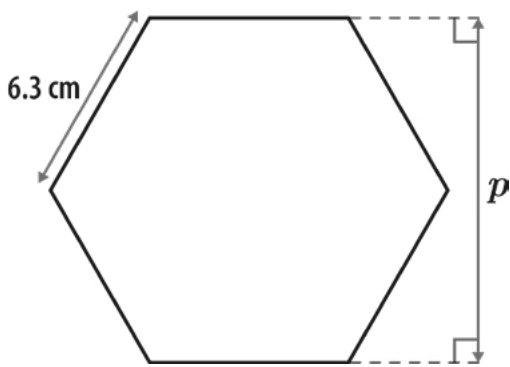

Not drawn accurately

Answer: ..... cm

Q1

Calculate the length  $d$ .  
Give your answer to 2 s.f.

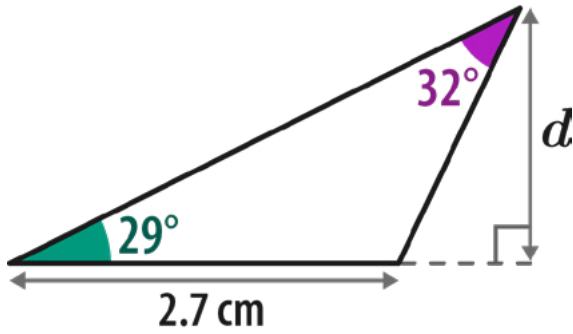

Not drawn accurately

Answer: ..... cm

Q2

Work out the length  $y$  in the triangle below.  
Give your answer in its simplest form, rationalising the denominator if necessary.

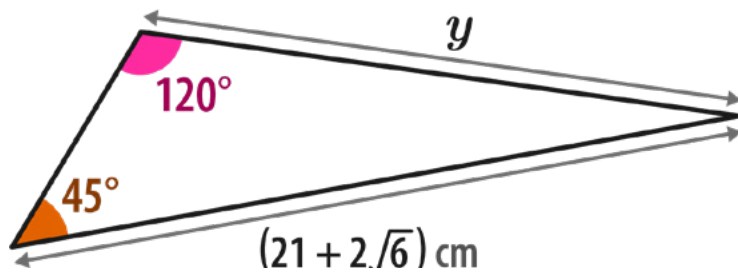

Not drawn accurately

Answer: ..... cm

**Q3** Using the information below, work out the value of  $x$ .

$$\sin A = \frac{4}{5} \qquad \sin B = \frac{3}{4}$$

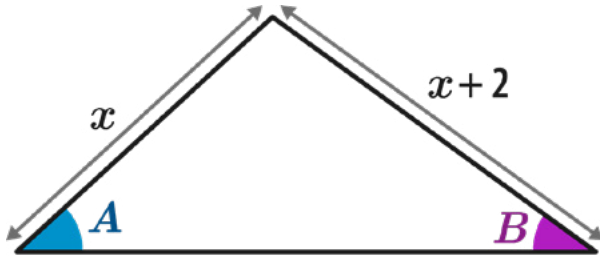

Not drawn accurately

Answer: .....

**Q4** Given that  $\cos\theta = \frac{1}{8}$  in the triangle below, show that  $y^2 = ax^2 + bx + c$  where  $a$ ,  $b$  and  $c$  are numbers.

What are the values of  $a$ ,  $b$  and  $c$ ?

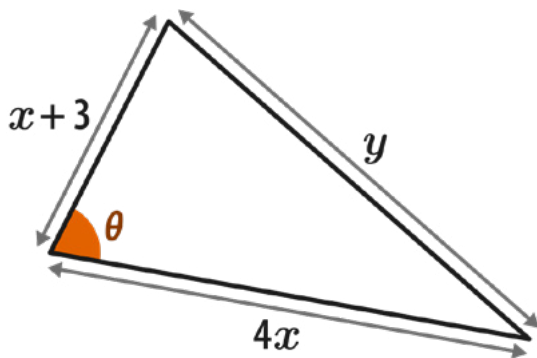

Not drawn accurately

Answer:  $a = \dots\dots\dots$   $b = \dots\dots\dots$   $c = \dots\dots\dots$